

## TH 356 and TH 357 Limitem Thermostats (Model 6)

### Product Description

The TH 356 Rigid Bulb Limitem and the TH 357 Remote Bulb Direct Acting Limitem are pneumatic thermostats with a variety of uses in unit ventilators and other air handling systems.

The TH 356 Rigid Bulb Limitem is available in either direct acting or reverse acting models. The TH 357 Remote Bulb Limitem is available in direct acting only.

### Product Numbers

#### TH 356 Limitem

Table 1. Rigid Bulbs.

Product No.	Action	Operating Range
356-0750	Direct Acting	30 to 180°F (-1 to 82°C)
356-1003		0 to 80°C (32 to 176°F)
356-0012		0 to 100°F (-18 to 38°C)
356-1005	Reverse Acting	30 to 180°F (-1 to 82°C)
356-1006		100 to 250°F (38 to 121°C)
356-1007		0 to 80°C (32 to 176°F)
356-1008		40 to 120°C (104 to 248°F)
356-0013		0 to 100°F (-18 to 38°C)

#### TH 357 Limitem

Table 2. Remote and Averaging Bulbs.

Product No.	Operating Range	Sensing Element	Bulb Inches (mm)	Capillary Ft (M)
357-0003	20 to 100°F (-7 to 38°C)	Remote Bulb	3/8 x 4 in. (9.5 x 102)	8 (2.4)
357-0013	-10 to 40°C (14 to 104°F)	Remote Bulb	3/8 x 4 in. (9.5 x 102)	8 (2.4)
357-0005	120 to 230°F (49 to 110°C)	Remote Bulb	3/8 x 4 in. (9.5 x 102)	40 (12.2)
357-0004	35 to 145°F (2 to 63°C)	Averaging Bulb	3/32" x 15 ft. (2.4 x 4570)	40 (12.2)
357-0001	35 to 145°F (2 to 63°C)	Averaging Bulb	3/32" x 8 ft. (2.4 x 2440)	0.5 (0.15)
357-0002	5 to 60°C (41 to 140°F)	Averaging Bulb	3/32" x 8 ft. (2.4 x 2440)	0.5 (0.15)

### Required Tools

- Drill and 1/4-inch (6.3 mm) and 5/8-inch (16 mm) drill bits  
3/16-inch (4.8 mm) and 9/16-inch (14 mm) drill bits for the mounting of the 808-412 mounting flange of kit 163-172
- Flat-blade screwdriver
- Test gauge and test thermometer

### Prerequisites

- Inspect the sensing tube for damage.
- Read the instructions to determine if any accessories are needed
- The use of supply and return (output pressure) air gauges and tees is recommended. Order Kit No. 142-0425 for gauge and tee for 1/8-inch NPT (two required).
- Provide adequate clearance for the sensing tube.

### Troubleshooting

If the Limitem fails to operate properly, use *Table 3* as a troubleshooting guide. Make certain the thermostat receives 18 to 30 psi (124 to 207 kPa) of clean, dry, oil free supply air. Also, use a test gauge with a length of 3/16-inch I.D. rubber hose to measure the return pressure at the test port if permanent gauges are not available.

## Troubleshooting, Continued

Table 3. Troubleshooting Chart.

Complaint	Check Supply Air Pressure	Probable Cause Low Pressure	Corrective Action As Required
Return Line pressure stays at approx. zero	Press down exhaust valve	If return is still zero psi	Replace thermostat
		If return pressure increases	1. Recalibrate 2. With 6 to 9 psi (41 to 62 kPa) return pressure, vary temperature at the bulb. If no change in return pressure, replace thermostat.
Return Line pressure stays at approx. supply pressure	Using a screwdriver, rotate set point dial counterclockwise to the limit stop	If return pressure remains high	Replace thermostat
		If return pressure drops to zero	Recalibrate
Excessive air leakage from exhaust valve	Supply and return line connection	Connections are interchanged	Reverse the supply and return connections

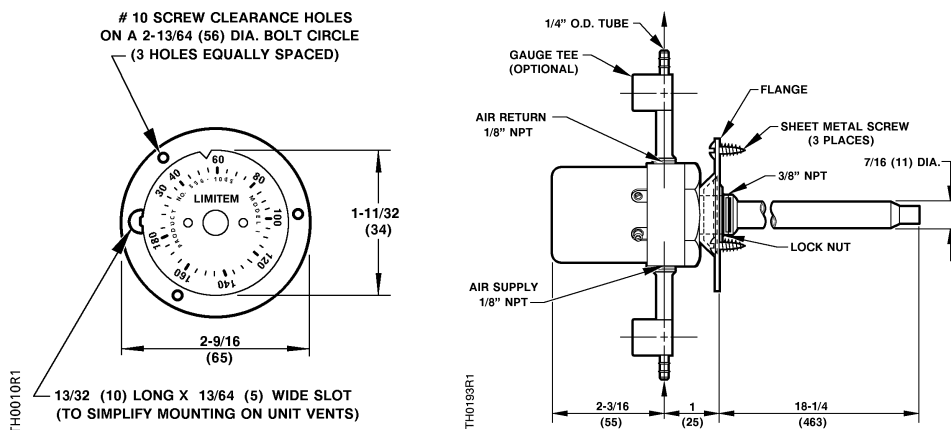

Figure 1. TH 356 Rigid Bulb Limitem.

## Installation

### TH 356 rigid bulb Limitem

#### Duct Mounting (See Figure 1)

Flange, lock-nut and sheet metal screws are provided for duct mounting.

1. Remove the flange from the Limitem and use the flange as a template. Mark the location of the center hole and three screw holes. Use 5/8-inch drill bit to drill the center hole and 1/4-inch drill bit for the screw holes.
2. Slip the flange over the rigid bulb and secure with the lock-nut.
3. Fasten the Limitem to the duct with the sheet metal screws provided.
4. Attach air gauges and tees in the supply and return lines.

#### Alternate Duct Mounting

The Swivel Flange Mounting Kit Part Number 356-090 is available for mounting the Limitem in ducts as small as 13-inches (330 mm) wide.

#### Swivel Flange Mounting (See Figure 2)

1. Use the swivel flange as a template to mark the location of the center hole and three screw holes.
2. Drill the holes and attach the flange.
3. Remove the standard mounting flange from the Limitem.
4. Carefully thread the Limitem through the 3/8-inch NPT tapped swivel socket.
5. Fasten the flange to the duct with the sheet metal screws provided.

## Installation, continued

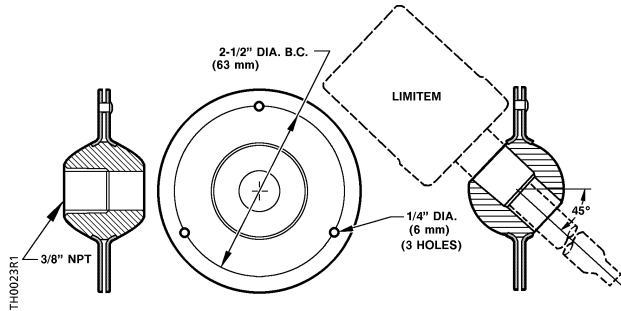

**Figure 2. Swivel Flange Mounting Kit  
 Part Number 356-090.**

### Well Mounting (See Figure 3)

- Exercise care when installing the Limitem into a well.
- The Limitem must fit freely in the well to operate properly.
- Screw the Limitem into the well finger tight.

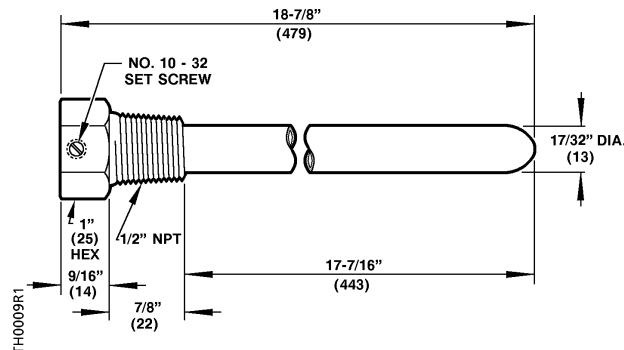

**Figure 3. Limitem Well Mounting Kit Part No. 358-051.**

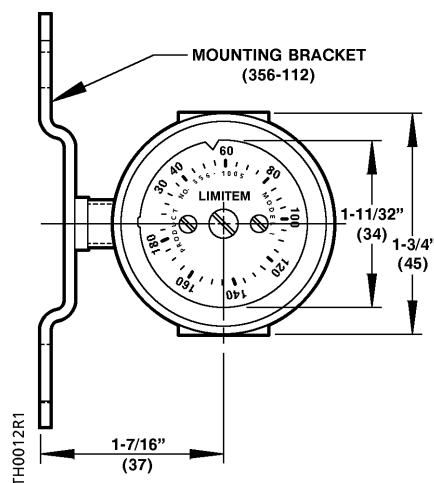

## TH 357 remote bulb and averaging bulb Limitem

### Mounting the TH 357 Limitem Body

(See Figure 4)

- A 1/8-inch NPT hole is provided for mounting.
- The mounting bracket furnished with the thermostat may be attached to any flat surface and the thermostat body threaded onto the protruding pipe nipple.
- When metal tubing is used for the supply and return air lines, this tubing may also serve to support the body of the thermostat.

### Mounting the TH 357 Limitem Bulb

- When mounting the bulb through a metal surface, protect the capillary by using a mounting flange with a rubber grommet in Kit 163-172.

### Remote Bulb

- Use a remote bulb holder Number 808-517 to support the remote bulb. The holder may be shortened to fit small ducts.
- When installing the remote bulb in a pipeline, use copper well Number 134-061.
- When the bulb is mounted in a unit ventilator, use coil clip Number 356-115 to support the bulb in the air stream through the coil. See Figures 6 and 7.

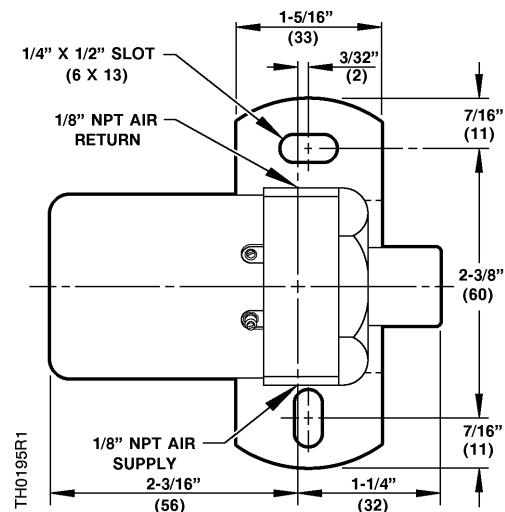

**Figure 4. TH 357 Remote and Averaging Bulb Limitem.**

## Installation, Continued

### Averaging Bulb Mounting

Averaging bulbs require some means of support for the bulb and capillary.

- Use a coil clip, Part Number 356-115 (Figures 6 and 7) or a capillary clip, Part Number 357-001 (Figure 5), to support the bulb if there is easy access to the coil.
- For duct mounting where access to the coil is limited, see Figure 8. Use flange Number 808-412 and a length of 3/8-inch (9.5 mm) O.D. hard copper tube to expose the bulb to the air leaving the coil within the duct.

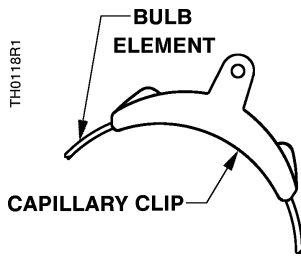

Figure 5. Capillary Clip Number 357-001 (Pkg of 100).

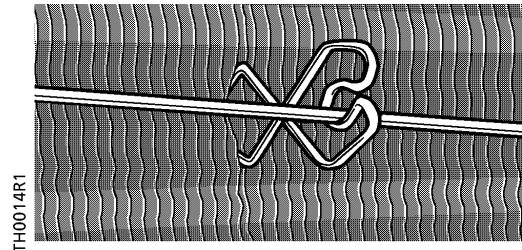

Figure 6. Clip Mounted on Coil.

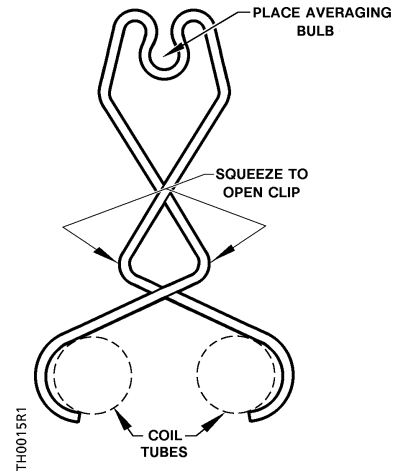

Figure 7. Coil Clip Number 356-115.

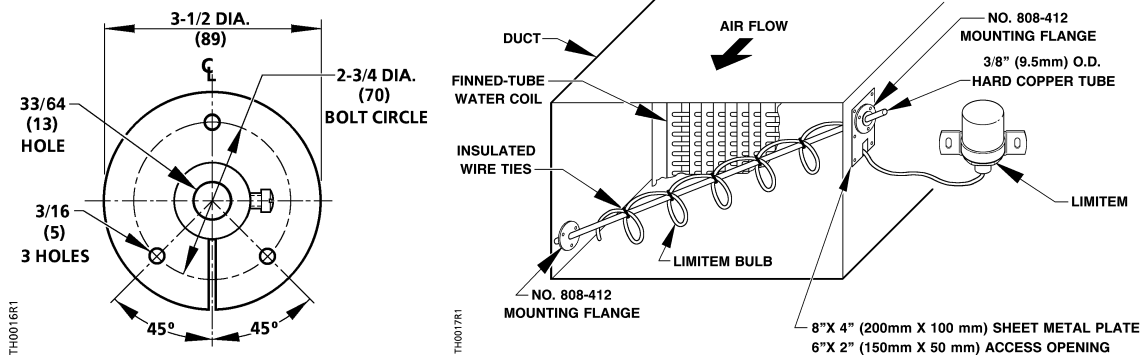

Figure 8. Installation of TH 357 Averaging Bulb in a Duct.

## Calibration

### Change set point

1. Remove the cover.
2. With a screwdriver, turn dial adjustment screw (Figure 9) to change to the desired set point.

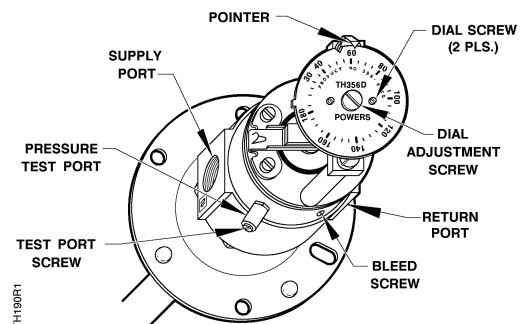

Figure 9. Limitem Cover Removed.

Siemens Building Technologies, Inc.

## Calibration, Continued

### Calibrate

- Using a test thermometer, accurately measure the temperature at the bulb.
- Set the dial to the bulb temperature by turning the dial adjustment screw with a screwdriver.

**NOTE:** You must use a screwdriver. Do not attempt to change the dial by rotating it with your hand.

- If a permanent return air gauge is not installed, use the pressure test port. See *Figure 9* for its location.
- Loosen the test port screw about 1/2 turn, and slip a 3/16-inch I.D. rubber hose connected to the test gauge over the pressure test port. See *Figure 10*.

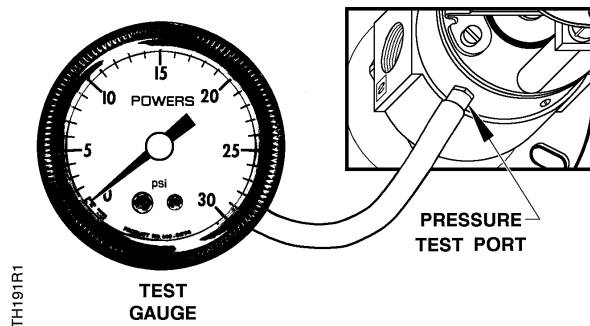

**Figure 10. Using the Pressure Test Port.**

- If the return pressure does not read 7 to 8 psi (48-55 kPa), turn the dial adjustment screw with a screwdriver until pressure is 7 to 8 psi (48-55 kPa).
- Loosen the dial screws and turn dial until the temperature at the bulb and dial is identical. Tighten the screws.
- The thermostat is now calibrated and the set point may be changed to desired set point.

### Sensitivity Adjustment

The sensitivity adjustment is factory set with the sensitivity spring tab in position 6 of the spring retainer. This is approximately mid span of the sensitivity. See *Table 4* for other settings.

**Table 4.**

Slot No	Sensitivity Psi/°F		
	Rigid Bulb	Remote Bulb	Rmt Bulb 40' Cap (12 m)
1	0.29	0.33	0.33
2	0.44	0.60	0.54
3	0.64	1.03	0.76
4	0.89	1.39	0.97
5	1.03	1.74	1.18
6	1.22	2.09	1.40
7	1.41	2.44	1.61
8	1.61	2.79	1.82
9	1.80	3.15	2.03
10	2.0	3.5	2.29
11	2.0	3.5	2.29

To change the sensitivity:

- Loosen the dial screws. (*Figure 9*)
- Loosen the dial adjustment screw.
- Lightly press the spring retainer. (Do not bend).
- Move the sensitivity spring to the new position. See *Figure 11*. *Table 4* gives the sensitivity spring tab location and the corresponding sensitivity value.

**NOTE:** The tab may be installed in either side of the spring retainer.

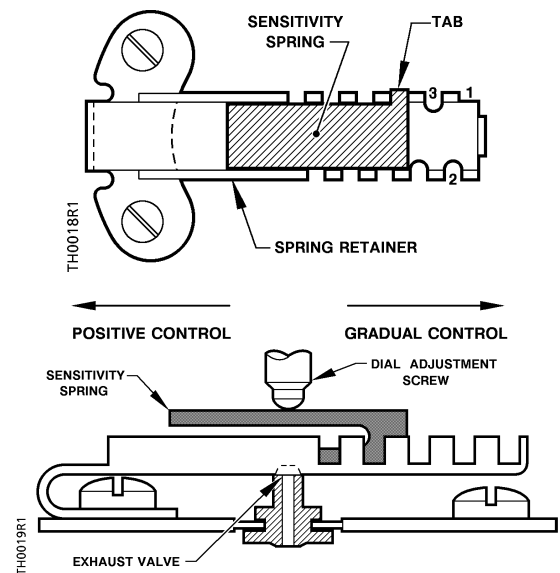

**Figure 11. Sensitivity Spring Setting.**

- Make sure that the dial adjustment screw point touches the sensitivity spring.
- Recalibrate the unit.

**Table 5. Cross Reference Chart.**

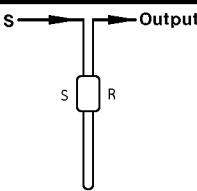
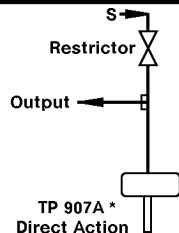
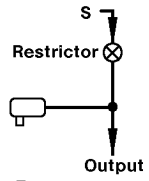
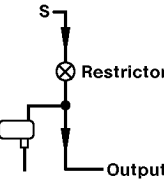
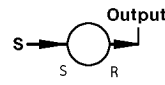
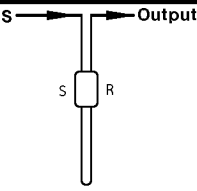
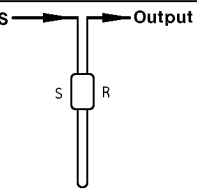
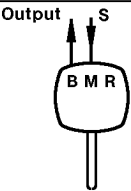
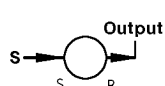
	SIEMENS BUILDING TECHNOLOGIES, INC.	HONEYWELL	JOHNSON	ROBERTSHAW	BARBER-COLEMAN	DISCONTINUED POWERS
	 <p>TH 358D Direct Action</p>	 <p>TP 907A * Direct Action</p>	 <p>T-3810* Direct Action</p>	 <p>T201* Direct Action</p>	 <p>TK 9637 Direct Action</p>	 <p>TH 360D Direct Action</p>
TH0021R2	 <p>TH358R Reverse Action</p>	—	—	 <p>T-130** Reverse Action</p>	 <p>TK 9737 Reverse Action</p>	—

\* Non-relay (one-pipe) requires external restrictor.

\*\* Direct or reverse acting-reversible.

## References

### Technical Instructions

TH 356-1  
 Limitem Thermostat  
 155-070P25

TH357-1  
 Remote Bulb Thermostat  
 155-071P25

TB 179  
 Remote Bulb Holder Kit  
 155-217P25

Information in this publication is based on current specifications. The company reserves the right to make changes in specifications and models as design improvements are introduced. © 2000 Siemens Building Technologies, Inc.